



INSTALLATION, OPERATION & MAINTENANCE MANUAL

FAHRENHEIT[®]
KB-F SERIES
TOP DISCHARGE
HEAVY DUTY DEWATERING WITH AGITATOR
Electric Submersible Pumps

CAST IRON
Three Phase
230V, 460V, & 575V

KB55-F
KB75-F
KB110-F

KB55H-F
KB75H-F
KB110H-F

Read this manual carefully before installing, operating or servicing these pump models. Observe all safety information. Failure to comply with instructions may result in personal injury and/or property damage. Please retain these instructions.

TABLE OF CONTENTS

INTRODUCTION.....	4
HSAFETY	4
INSPECTION	5
PRE-INSTALLATION INSPECTION	5
OIL FILL QUANTITY/TYPE	6
PUMP INSTALLATION	6
POSITIONING THE PUMP	6
PUMP ROTATION	7
PUMP OPERATION.....	8
TYPICAL MANUAL DEWATERING INSTALLATION.....	8
STOPPING.....	9
TYPICAL AUTOMATIC DEWATERING INSTALLATION	9
STOPPING.....	10
INTENDED METHODS OF CONNECTION.....	10
THREE PHASE WIRING INSTRUCTION	10
TROUBLE SHOOTING	12
PUMP WILL NOT RUN	12
PUMP RUNS BUT DOES NOT DELIVER RATED CAPACITY.....	12
SERVICING YOUR SUBMERSIBLE PUMP.....	12
MAINTAINING YOUR PUMP	13
CHANGING SEAL OIL	13
CHANGING SEALS*.....	13
EXPLODED VIEW OF KB55-F, 55H-F, 75-F, 75H-F, 110-F, 110H-F	15
KB-F SERIES PARTS LIST	16
THREE PHASE WIRING DIAGRAMS	17
230V.....	17
MODELS KB55-F, 55H-F, 75-F, 75H-F, 110-F, 110H-F.....	18
460V.....	18
MODELS KB55-F, 55H-F, 75-F, 75H-F, 110-F, 110H-F.....	18
575V.....	19
MODELS KB55-F, 55H-F, 75-F, 75R-F, 110-F, 110H-F.....	19
SEAL MINDER® - THERMAL MOTOR SENSOR SWITCH.....	20
WARRANTY AND LIMITATION OF LIABILITY.....	22
START-UP REPORT FORM.....	23
NOTES:.....	26



INTRODUCTION

This Installation, Operation and Maintenance manual provides important information on safety and the proper inspection, disassembly, reassembly and testing of the BJM Pumps® KB-F Series submersible pump. This manual also contains information to optimize performance and longevity of your BJM submersible pump. The F Series Fahrenheit pumps are engineered to pump water based liquids up to 200°F (93°C).

The submersible KB-F Series pumps are designed to pump water. The KB-F Series pumps are not explosion-proof. They are not designed to pump volatile or flammable liquids.

Note: Consult chemical resistance chart for compatibility between pump materials and liquid before operating pump.

If you have any questions regarding the inspection, disassembly, re-assembly or testing please contact your **BJM Pumps** distributor, or BJM Pumps, LLC.

BJM Pumps, LLC
123 Spencer Plain Rd.
Old Saybrook, CT 06475, USA

Fax: 860-399-7784
Phone: 877-256-7867
Phone: 860-399-5937

Information, including pump data sheets and performance curves, is also available on our web site: www.bjmpumps.com

For assistance with your electric power source, please contact a certified electrician.

Please pay attention to the following alert notifications. They are used to notify operators and maintenance personnel to pay special attention to procedures, to avoid causing damage to the equipment, and to avoid situations that could be dangerous to personnel.

NOTE: Instructions to aid in installation, operation, and maintenance or which clarify a procedure.

 **DANGER** Immediate hazards that WILL result in severe personal injury or death. These instructions describe the procedure required and the injury which will result from failure to follow the procedure.

 **WARNING** Hazards or unsafe practices that COULD result in severe personal injury or death. These instructions describe the procedure required, and the injury which could result from failure to follow the procedure.



⚠ CAUTION Hazards or unsafe practices which COULD result in personal injury or product or property damage. These instructions describe the procedure required and the possible damage which could result from failure to follow the procedure.

SAFETY

Pump installations are seldom identical. Each installation and application can vary due to many different factors. It is the owner/service mechanics responsibility to repair, service, and test to ensure that the pump integrity is not compromised according to this manual.

⚠ WARNING Risk of electric shock – this pump has not been investigated for use in swimming pool areas.

⚠ DANGER **Do not pump flammable, inflammable or volatile liquids. Death or serious injury will result.**

⚠ WARNING Before attempting to open or service the pump:

- 1) Familiarize yourself with this manual.
- 2) Unplug or disconnect the pump power cable to ensure that the pump will remain inoperative.
- 3) Allow the pump to cool if overheated.

⚠ WARNING Do not operate the pump with a worn or damaged electric power cable. Death or serious injury could occur.

⚠ WARNING Never attempt to alter the length or repair any power cable with a splice. The pump motor and pump motor and cable must be completely waterproof. Damage to the pump or personal injury may result from alterations.

⚠ WARNING After the pump has been installed, make sure that the pump and all piping are secure before operation.

⚠ WARNING Do not lift the pump by the power cable piping or discharge hose. Attach proper lifting equipment to the lifting handle (or lifting rings) fitted to the pump. Do not suspend the pump by the power cable.

⚠ WARNING Obtain the services of a qualified electrician to troubleshoot, test and/or service the electrical components of this pump.



Pumps and related equipment must be installed and operated according to all national, local and industry standards.

INSPECTION

Review all safety information before servicing pump.

The following are recommended installation practices/procedures for the pump. If there are questions in regards to your specific application, contact your local **BJM Pumps** distributor or BJM Pumps, LLC.

PRE-INSTALLATION INSPECTION

- 1) Check the pump for damage that may have occurred during shipment.
- 2) Inspect the pump for any cracks, dents, damaged threads, etc.
- 3) Check power cord (and seal minder cord, if installed) for any cuts or damage.
- 4) Check for, and tighten any hardware that appears loose.
- 5) Carefully read all tags, decals and markings on the pump.
- 6) **Important:** Always verify that the pump nameplate, amps, voltage, phase, and HP ratings match your control panel and power supply.

Warranty does not cover damage caused by connecting pumps and controls to an incorrect power source (voltage/phase supply). Record the model numbers and serial numbers from the pumps and control panel on the front of this instruction manual for future reference. Give it to the owner or affix it to the control panel when finished with the installation.

If anything appears to be abnormal, contact your **BJM Pumps** distributor or BJM Pumps, LLC. If damaged, the pump may need to be repaired before use. Do not install or use the pump until appropriate action has been taken.

Lubrication:

No additional lubrication is necessary. The shaft seal and bearings are fully lubricated from the factory. Seal oil should be checked once per year. See table below.



OIL FILL QUANTITY/TYPE

Models	Qty. oil in seal chamber		
	U.S. fl. oz.	C.C.	Type of oil
KB55-F, 55H-F, 75-F, 75H-F, 110-F, 110H-F	49	1450	ISO 32 NSF Food Grade Mineral Oil

Note: The stator on this model is oil filled. This needs to be changed annually when the seal oil is changed. With the power cable entry removed, fill the motor chamber with oil to a level that insures the oil is covering the motor windings by 1/2", and that will be above the upper bearing. Do not overfill, an air gap of 10-15% must be maintained for heat expansion

PUMP INSTALLATION

KB-F Series pumps have been evaluated for use with water or water based solutions. Please contact the manufacturer for additional information.

⚠ WARNING

Risk of electric shock. KB-F Series pump models do not come with electric plug connectors. To reduce the risk of electric shock, be certain that it is connected only to a properly grounded, grounding-type receptacle.

Lifting:

Attach a rope or lifting chain (not included) to the handle (or lifting rings) on the top of the pump.

⚠ CAUTION

Do not lift the pump by the power cable or discharge hose/piping. Proper lifting equipment (rope/chain) must be used.

POSITIONING THE PUMP

BJM Pumps, KB-F Series pumps are designed to operate fully or partially submerged. Do not run pumps dry. Refer to data sheet for minimum submersion depth for your particular model. Data sheets can be obtained online at www.bjmpumps.com or by calling BJM Pumps, LLC at 860-399-5937. As a general rule, KB-F Series top discharge pumps can pump down to a level above the suction screen. Pumping lower than screen will permit air to enter the pump and cavitate, lose prime or become air bound.

CAUTION

- Do not run pump dry.
- Pump liquid should not exceed a maximum temperature of 200°F (93°C).
- Never place the pump on loose or soft ground. The pump may sink, preventing water from reaching the impeller. Place on a solid surface or suspend the pump with a lifting rope/chain. The KB-F Series pumps are provided with a suction strainer to prevent large solids from clogging the impeller. Any spherical solids which pass through the strainer should pass through the pump.
- For maximum pumping capacity, use the proper size non-collapsible hose or rigid piping. A check valve may be installed after the discharge to prevent back flow when the pump is shut off.

PUMP ROTATION

Two ways to check the correct pump rotation:

1. By looking at the impeller; the rotation of the impeller should be counter clockwise as shown in the picture below.

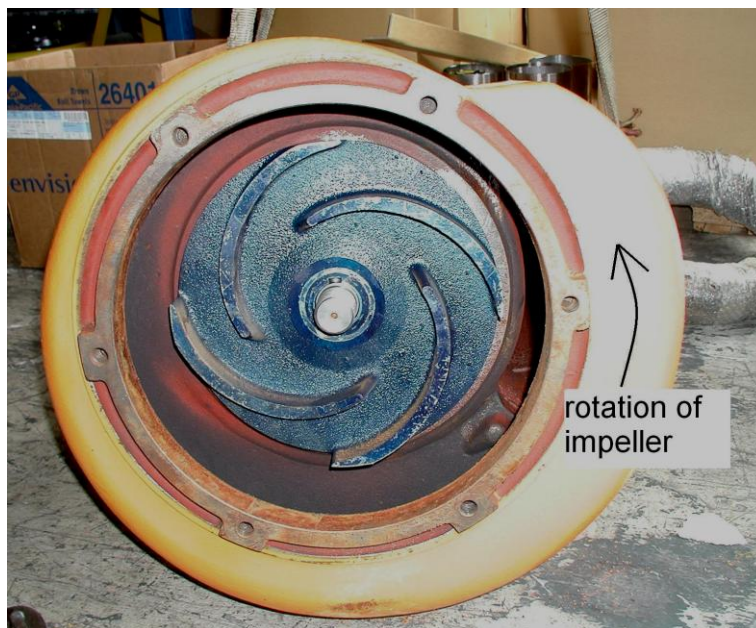



2. By looking from the top of the pump. Since the impeller cannot be seen, the best way to check the rotation is to check the kick back motion of the pump when the pump just starts. The kick back motion of the pump should be counter clockwise as shown in the picture below.



PUMP OPERATION

⚠ WARNING

This pump is designed to handle dirty water that contains some solids. It is not designed to pump volatile, or flammable liquids. Do not attempt to pump any liquids which may damage the pump or endanger personnel as a result of pump failure.

⚠ DANGER

Do not operate this pump where explosive vapors or flammable material exist. Death or Serious injury will result.

TYPICAL MANUAL DEWATERING INSTALLATION

NOTE: Maximum recommended starts should not exceed 10 times per hour.

All KB-F models are provided with a 50' (10m) power cord. NEVER splice the power cable due to safety and warranty considerations. Always keep the lead end dry.

Note: 230V, 460V & 575V three phase units do not have a plug and have to be provided separately.



⚠ WARNING

Do not alter the length or repair any power cable with a splice. The pump motor and cable must be completely waterproof. Damage to the pump or personal injury may result from alterations.

For manual operation: 230, 460 & 575 volt: Attach the proper plug or connect directly to the power source or control box. Check the direction of the rotation. Tilt the pump and start it. It should twist in the opposite direction of the arrow (on pump). It is recommended that a Ground Fault Interrupter (GFI) type receptacle (or equivalent) be used.

STOPPING

To stop the pump (manual and automatic mode), unplug it from the power source, turn off the breaker, or turn the power source off (generator).

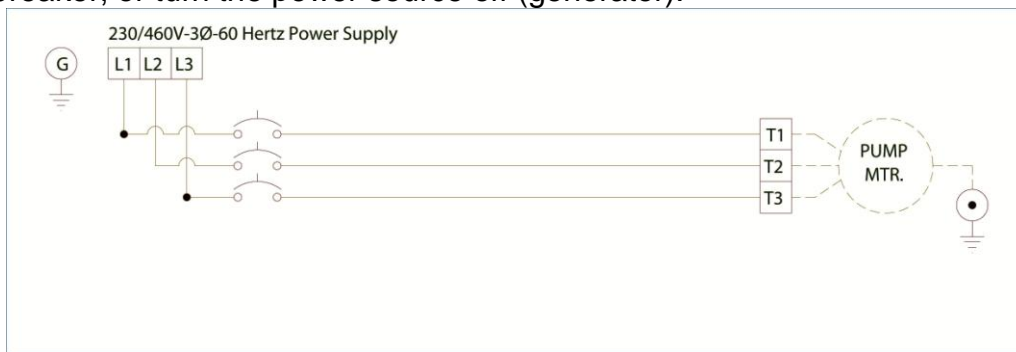

Typical 3 Phase Manual Control 1

TYPICAL AUTOMATIC DEWATERING INSTALLATION

NOTE: Maximum recommended starts should not exceed 10 times per hour.

Three phase pumps need a separate control box with float(s) for automatic operation.

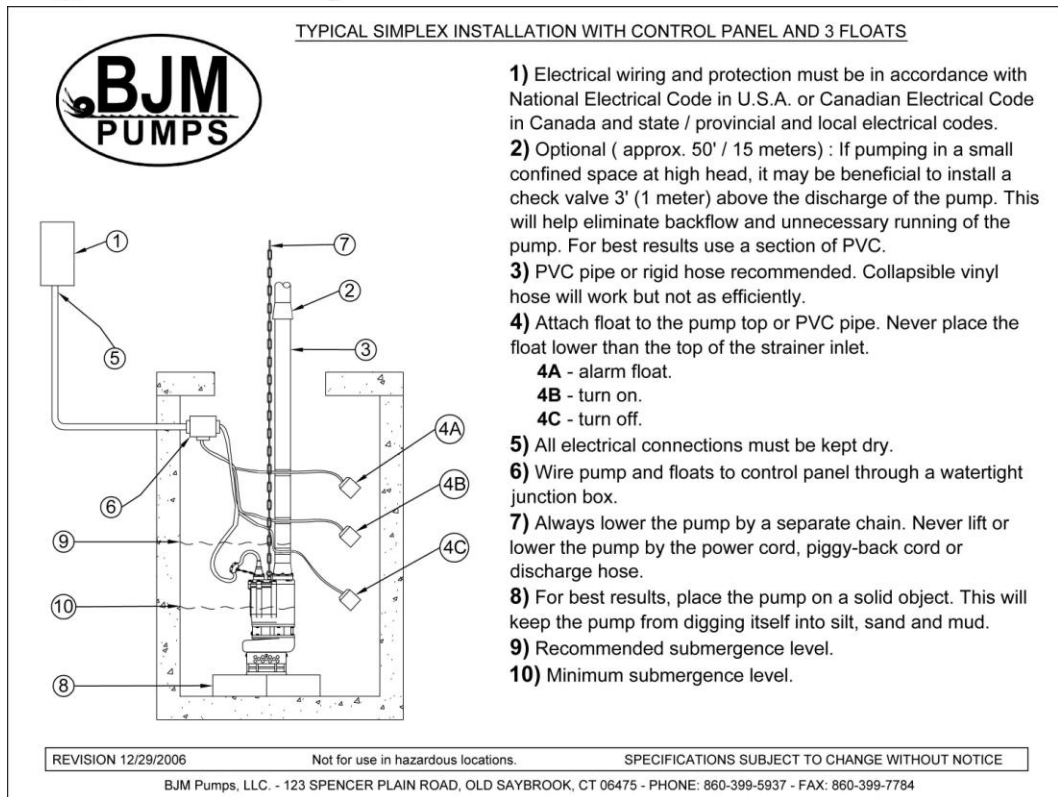

STOPPING

To stop the pump (manual and automatic mode), unplug it from the power source, turn off the breaker, or turn the power source off (generator).

INTENDED METHODS OF CONNECTION

⚠ CAUTION Use with approved motor control that matches motor input in full load amperes. "UTILISER UN DÉMARREUR APPROUVÉ CONVARIANT AU COURANT À PLEINE CHARGE DU MOTEUR."

BJM Pumps has been evaluated for use with water or water based solutions. Please contact the manufacturer for additional information.

THREE PHASE WIRING INSTRUCTION

⚠ WARNING FOR YOUR PROTECTION, ALWAYS DISCONNECT PUMP FROM ITS POWER SOURCE BEFORE HANDLING.

⚠ WARNING "Risk of electrical shock" Do not remove power supply cord and strain relief or connect conduit directly to the pump.



WARNING Installation and checking of electrical circuits and hardware should be performed by a qualified licensed electrician.

To automatically operate a non-automatic three phase pump, a control panel is required. Follow the instructions provided with the panel to wire the system. For automatic three phase pumps see automatic three phase wiring diagram.

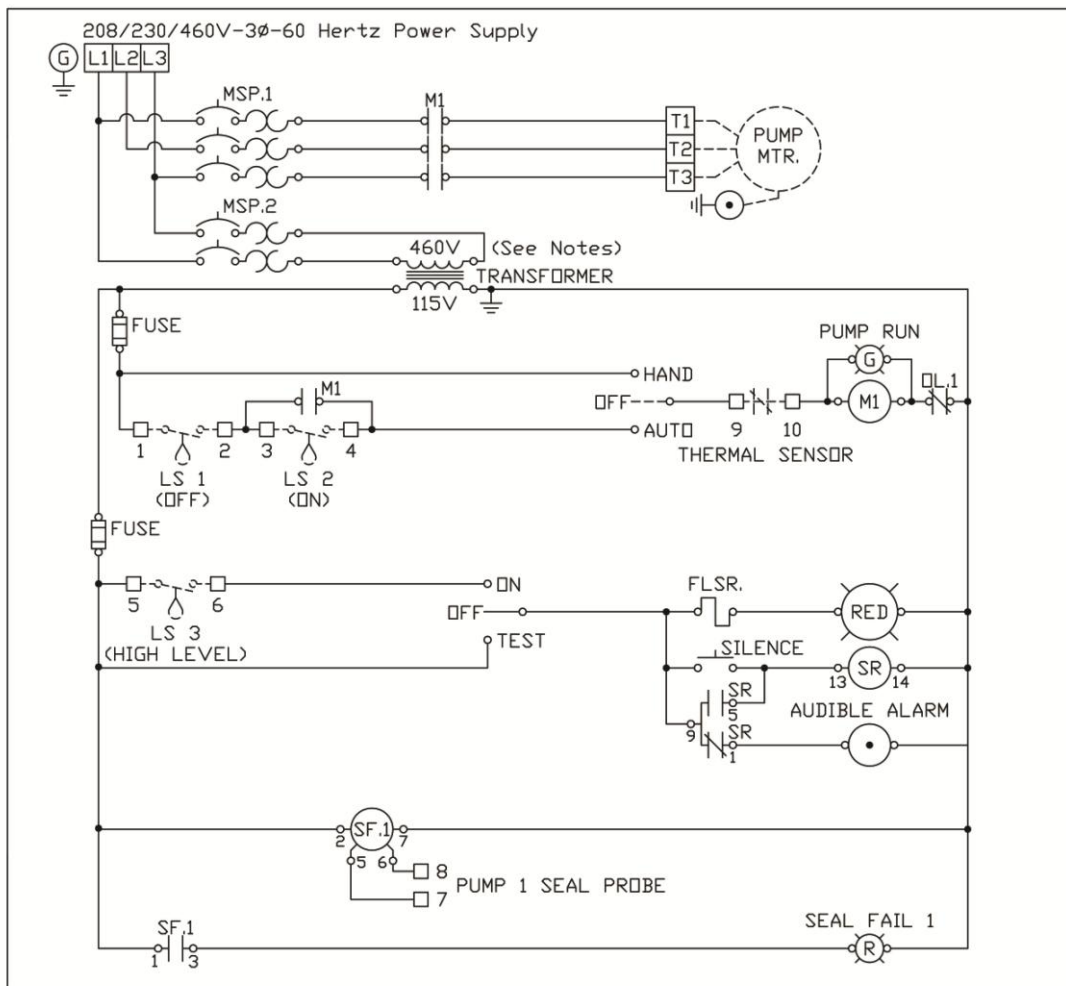

Typical 3 Phase Auto Control 1

Before installing a pump, check the pump rotation to insure that wiring has been connected properly to power source, and that the green lead of power cord (See wiring diagram), is connected to a valid ground, momentarily energize the pump, observing the directions of kick back due to starting torque. Rotation is correct if kick back is in the opposite direction of rotation arrow on the pump casing. If rotation is not correct, switching of any two power leads other than ground will provide the proper rotation.

BJM three phase pumps do not have integral motor overload protection. BJM recommends that all three phase pumps using a motor starting device also incorporate



motor overload protection. Pumps **must** be installed in accordance with the National Electrical Code and all applicable local codes and ordinances. Pumps are not to be installed in locations classified as hazardous in accordance with National Electrical Code, ANSI/NFPA 70.

Connect pump to a junction box, outlet box, control box, enclosure with a wiring compartment that meets NEC and local codes. The provision for supply connection shall reduce the risk of water entry during temporary, limited submersion and shall comply with the applicable requirements of the Standard for Enclosures for Electrical Equipment, UL 50, or the standard for Metallic Outlet Boxes, UL 514A, and the standard for Motor-Operated Water Pumps. UL 778.

TROUBLE SHOOTING



Disconnect the power source to the pump BEFORE attempting any type of trouble shooting, service or repair.

PUMP WILL NOT RUN

1. Check power supply (fuses, breaker). Reset power.
2. Blocked impeller. Remove strainer, check and clean.
3. Defective cable or incorrect wiring.
4. Strainer clogged. Check and clean as necessary.
5. Float switch tangled/obstructed. Clean and free float switch from obstruction.
6. Float switch defective. Replace float switch.
7. Pump overheated or temperature of liquid exceeds pump operating temperature.

PUMP RUNS BUT DOES NOT DELIVER RATED CAPACITY

1. Discharge line clogged, restricted or hose kinked. Check discharge hose/pipe.
2. Worn impeller and/or suction cover. Inspect and replace as necessary.
3. Pump overloaded due to liquid pumped being too thick.
4. Pumping air. Check liquid level and position of pump.
5. Excessive voltage drops due to long cables.
6. Three phase only; pump running backwards, check rotation.

SERVICING YOUR SUBMERSIBLE PUMP

Pump should be disconnected from the electric power supply before proceeding to do any service or maintenance.

To service or repair your pump, please contact your local **BJM Pumps** distributor. Service should only be performed by a qualified electrician. The design of the "F" series high temperature pump models is unique and requires specific knowledge to perform the proper assembly. BJM Pumps recommends that all electrical service work be



performed at the factory or by a factory trained and certified repair technician to insure that the materials and assembly methods meet BJM standards.

MAINTAINING YOUR PUMP

- Pump must be disconnected from the electric power supply before proceeding to do any service or maintenance.
- Pump should be inspected at regular intervals for wear.
- More frequent inspections are required if the pump is used in a harsh environment, such as pumping abrasive solids or high/low PH water.
- Preventative maintenance should be performed to reduce the chance of premature failure.
- Worn impeller wear plates and lip seals should be replaced.
- Cut or cracked power cords must be replaced. **(Never operate a pump with a cut, cracked or damaged power cord.)**
- Seal oil should be checked once per year.
- Maintenance should always be done when taking a pump out of service before storage.
 - 1) Clean pump of dirt and other build up.
 - 2) Check condition of oil around the shaft seals.
 - 3) Check hydraulic parts: check for wear.
 - 4) Inspect power cable. Make sure that it is free of nicks or cuts.

CHANGING SEAL OIL

Changing the seal oil in the KB-F Series pumps is very easy.

- 1) Make sure that the pump cable is disconnected from the power source.
- 2) Lay the pump down on its side.
- 3) Remove the screws that hold the bottom plate in place.
- 4) Remove bottom plate.
- 5) Remove screws holding the suction cover.
- 6) Remove the suction cover.
- 7) Remove the impeller.
- 8) Remove the inspection screw for the oil chamber (pos#50-08). Pour out a small sample of the oil. If it is milky white, or contains water, then the oil and possible, the mechanical seal, should be changed. If an oil change is needed:
- 9) Remove the screws that hold the oil chamber cover in place & remove the oil.
- 10) Replace the mechanical seal if necessary.
- 11) Replace the oil.
- 12) Reassemble the pump.

CHANGING SEALS*

- 1) Make sure that the pump cable is disconnected from the power source.
- 2) Lay the pump down on its side.



- 3) Remove the oil inspection bolt (pos#50-11) from the oil seal chamber.
- 4) Drain out all the inside the oil seal chamber.
- 5) Remove the bolts holding the stand.
- 6) Remove the stand.
- 7) Remove the bolts holding the suction cover.
- 8) Remove the suction cover.
- 9) Remove the agitator.
- 10) Remove the impeller, impeller key and shims.
- 11) Remove the bolts holding the pump housing.
- 12) Remove the pump housing.
- 13) Remove the shaft sleeve. Note the shaft sleeve direction.
- 14) Remove the bolts holding the oil cover.
- 15) Remove the oil cover.
- 16) Remove the screws holding the seal retainer.
- 17) Remove the seal retainer.
- 18) Remove the mechanical seal.
- 19) Replace the mechanical seal, lip seal and o-rings.
- 20) Reassemble the pump.
- 21) Fill with recommended new oil.
- 22) Replace the oil inspection bolt o-ring.
- 23) Secure the oil inspection bolt.
- 24) Reassemble the remainder of pump in reverse order of disassembly.

*Note: If there is excessive liquid found in the oil or mechanical seal damaged, please contact BJM authorized service centers.

STATOR REPLACEMENT OR ELECTRICAL REPAIR

The BJM Pumps "F" Series designed pumps utilize unique construction methods and materials. The interconnection of all wiring requires the use of a BJM wire connection kit. Included in this kit are specific instructions on how a qualified factory trained and certified repair technician can perform this work properly. No other materials or methods should be used on this product.

EXPLODED VIEW OF KB55-F, 55H-F, 75-F, 75H-F, 110-F, 110H-F

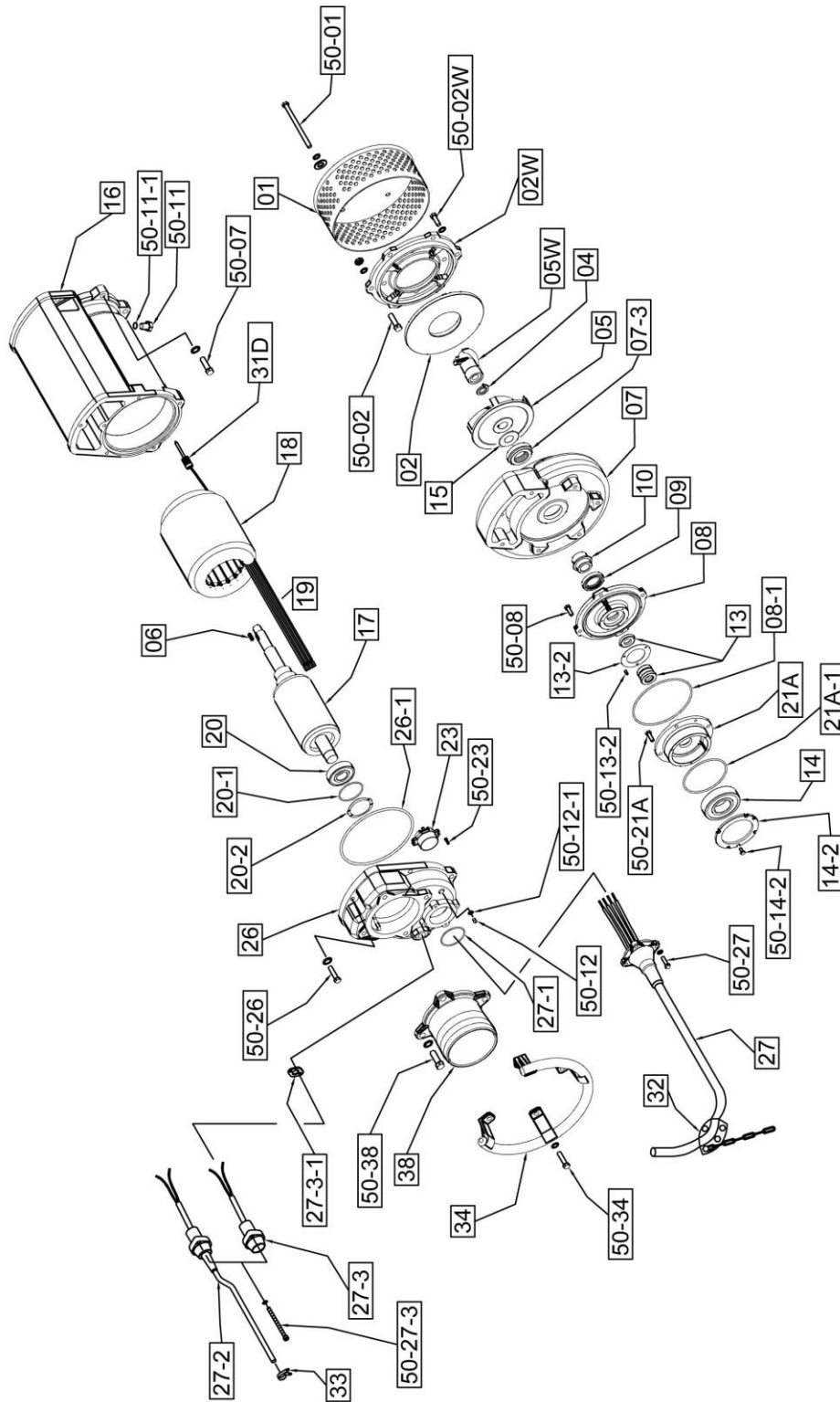

KB-F SERIES PARTS LIST

	Pump Model	KB55-F	KB55H-F	KB75-F	KB75H-F	KB110-F	KB110H-F
Pos. No.	Part Description	Item #	Item #	Item #	Item #	Item #	Item #
01	Strainer / Stand	202013	202013	202014	202013	202014	202014
02	Wear Plate	202863	202866	202865	202866	202024	202025
02W	Suction Cover	202878	202878	202879	202878	202879	202879
04	Lock Washer	202904	202904	202904	202904	202904	202904
05	Impeller	202924	202925	202926	202927	202928	202929
05W	Agitator	202058	202058	202058	202058	202058	202058
06	Impeller Key	202145	202145	202145	202145	202145	202145
07	Pump Housing	203036	203036	203033	203036	203033	203033
07-3	Pump Housing Sleeve	202182	202182	202182	202182	202182	202182
08	Oil Chamber Cover	202228	202228	202228	202228	202228	202228
08 -1	O-Ring (Kit Only)	Kit	Kit	Kit	Kit	Kit	Kit
09	Lip Seal FKM	202250	202250	202250	202250	202250	202250
10	Shaft Sleeve	203074	203074	203074	203074	203074	203074
13	Mech. Seals - Set FKM	201015	201015	201015	201015	201015	201015
13-2	Mech. Seal Retainer	202274	202274	202274	202274	202274	202274
14	Lower Ball Bearing	200963	200963	200963	200963	200962	200962
14-2	Lower Bearing Retainer	202276	202276	202276	202276	202282	202282
15	Impeller Shim Kit (Required)	200478	200478	200478	200478	200478	200478
16	Motor Housing	203078	203078	203079	203078	203080	203080
17	Rotor w/ Shaft, 3 phase	204047	204047	204048	204048	204049	204049
18	Stator 230V/460V, 3 phase, 60Hz	200675	200675	-	-	-	-
18	Stator, 460V, 3 phase, 60Hz	-	-	203903	203903	203905	203905
18	Stator 575V, 3 phase, 60 Hz	203906	203906	203907	203907	203909	203909
19	Wire Connection Kit*	204203	204203	204203	204203	CTF	CTF
20	Upper Ball Bearing	200968	200968	200968	200968	200968	200968
20-2	Spring Washer	202361	202361	202361	202361	202361	202361
21A	Lower Bearing Housing	202376	202376	202376	202376	202375	202375
21A-1	O-Ring (Kit Only)	Kit	Kit	Kit	Kit	Kit	Kit
26	Pump Top Cover	203133	203133	203134	203133	203134	203134
26-1	O-Ring (Kit Only)	Kit	Kit	Kit	Kit	Kit	Kit
27	Power Cord Set (4 lead) High Temp	203890	203890	203890	203890	203891	203891
27-1	O-Ring (Kit Only)	Kit	Kit	Kit	Kit	Kit	Kit
27-2	Seal Minder/High Temp Sensor Cable	201742	201742	201742	201742	201742	201742
27-3-1	O-Ring (Kit Only)	Kit	Kit	Kit	Kit	Kit	Kit
31D	Seal Minder Sensor	202410	202410	202410	202410	202410	202410
32	Power Cable Strain Relief	202497	202497	202497	202497	202500	202500
33	Seal Minder Cord Line Clip	203163	203163	203163	203163	203163	203163
34	Handle	202527	202527	202528	202527	202528	202528
38	3" NPT Male Coupling Flange	-	202610	-	-	-	-
38	4" NPT Male Coupling Flange	202609	-	-	202609	-	202612
38	6" NPT Male Coupling Flange	-	-	202611	-	202611	-
50-01	Bolt - Strainer / Stand	203241	203241	203225	203241	203225	203225
50-02	Bolt - Wear Plate	203294	203294	203262	203294	203262	203262
50-02W	Bolt - Suction Cover	203262	203262	203262	203262	203262	203262
50-07	Bolt - Pump Housing	203265	203265	203265	203265	203265	203265
50-08	Bolt - Oil Chamber Cover	203229	203229	203229	203229	203229	203229
50-11	Bolt - Oil Inspection	203268	203268	203268	203268	203268	203268
50-11-1	O-Ring (Kit Only)	Kit	Kit	Kit	Kit	Kit	Kit
50-12	Screw - Pressure Test	203218	203218	203218	203218	203218	203218
50-12-1	O-Ring (Kit Only)	Kit	Kit	Kit	Kit	Kit	Kit
50-13-2	Screw - Seal Retainer	203214	203214	203214	203214	203214	203214
50-14-2	Bolt - Bearing Retainer	203219	203219	203219	203219	203219	203219
50-21A	Bolt - Bearing Housing	203229	203229	203229	203229	203229	203229
50-26	Bolt-Top Cover	-	-	203223	-	203223	203223
50-27	Bolt - Power Cord	203229	203229	203229	203229	203229	203229
50-27-3	Screw - Seal Minder Cap	203216	203216	203216	203216	203216	203216
50-34	Bolt - Handle	203222	203222	203222	203222	203222	203222
50-38	Bolt - Discharge Flange	203262	203262	203224	203262	203224	203224
O-Ring Kit - FKM		203753	203753	203753	203753	203753	203753

"F" Series High Temperature Pumps Only

THREE PHASE WIRING DIAGRAMS

230V

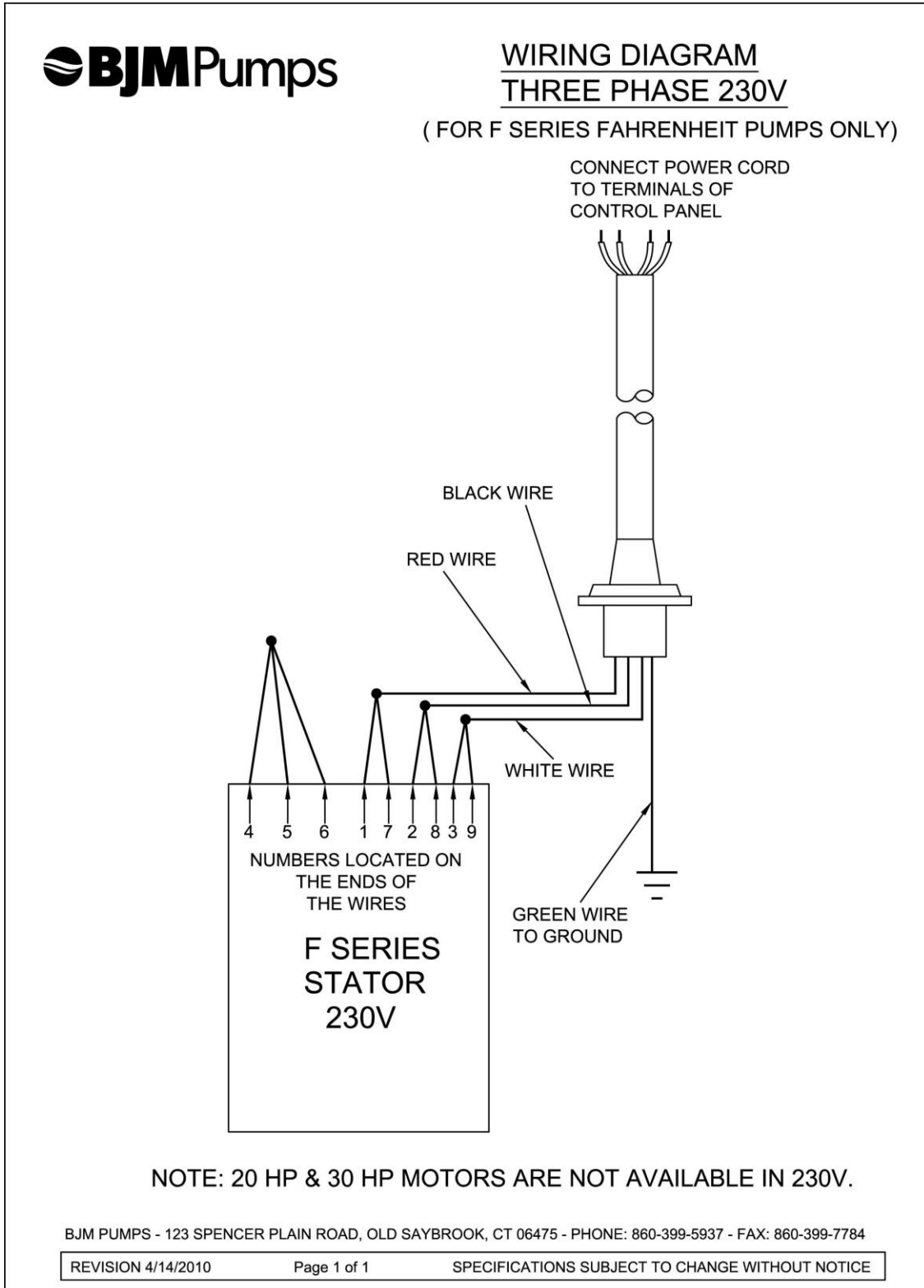

MODELS KB55-F, 55H-F, 75-F, 75H-F, 110-F, 110H-F

460V

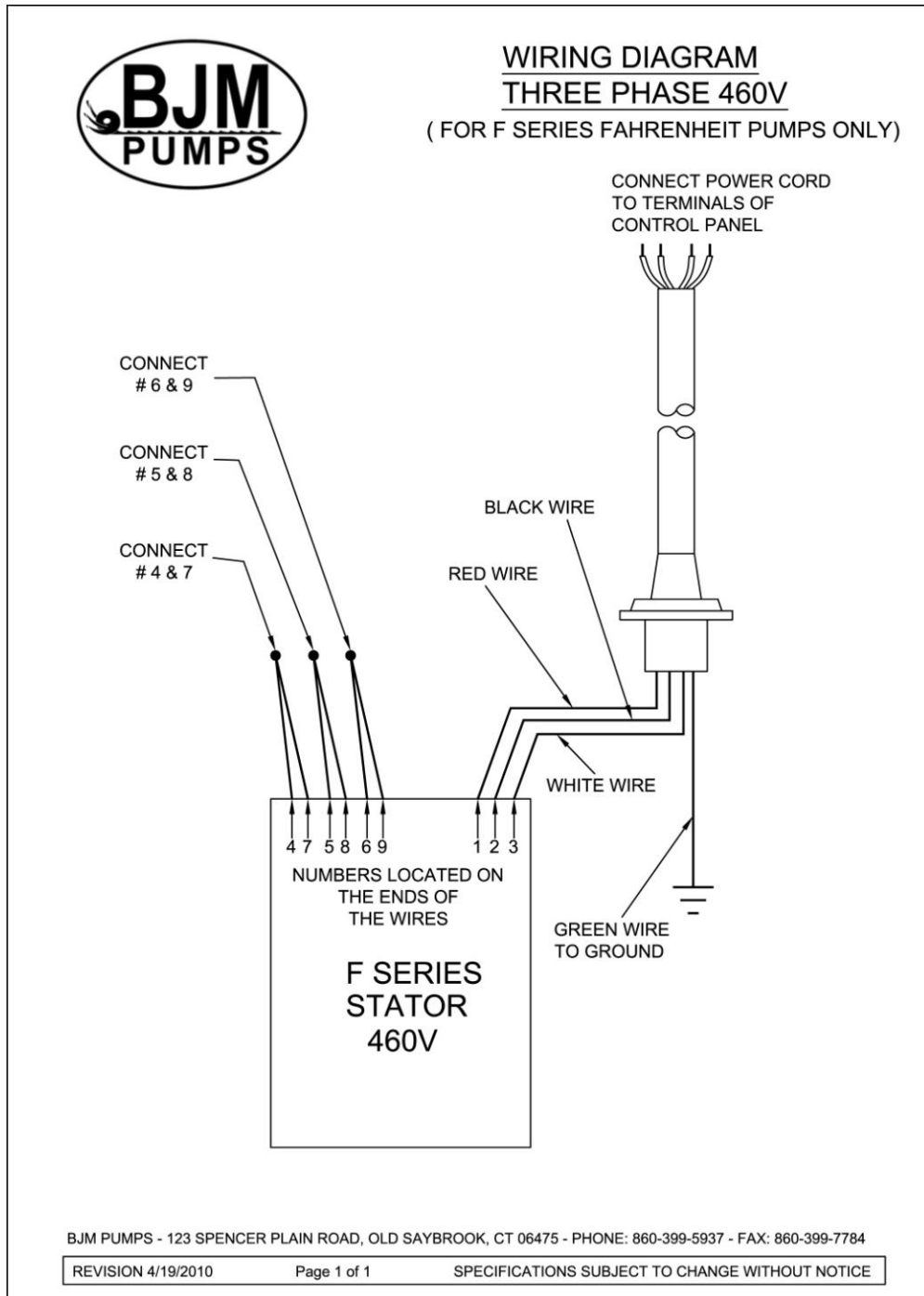

MODELS KB55-F, 55H-F, 75-F, 75H-F, 110-F, 110H-F

575V

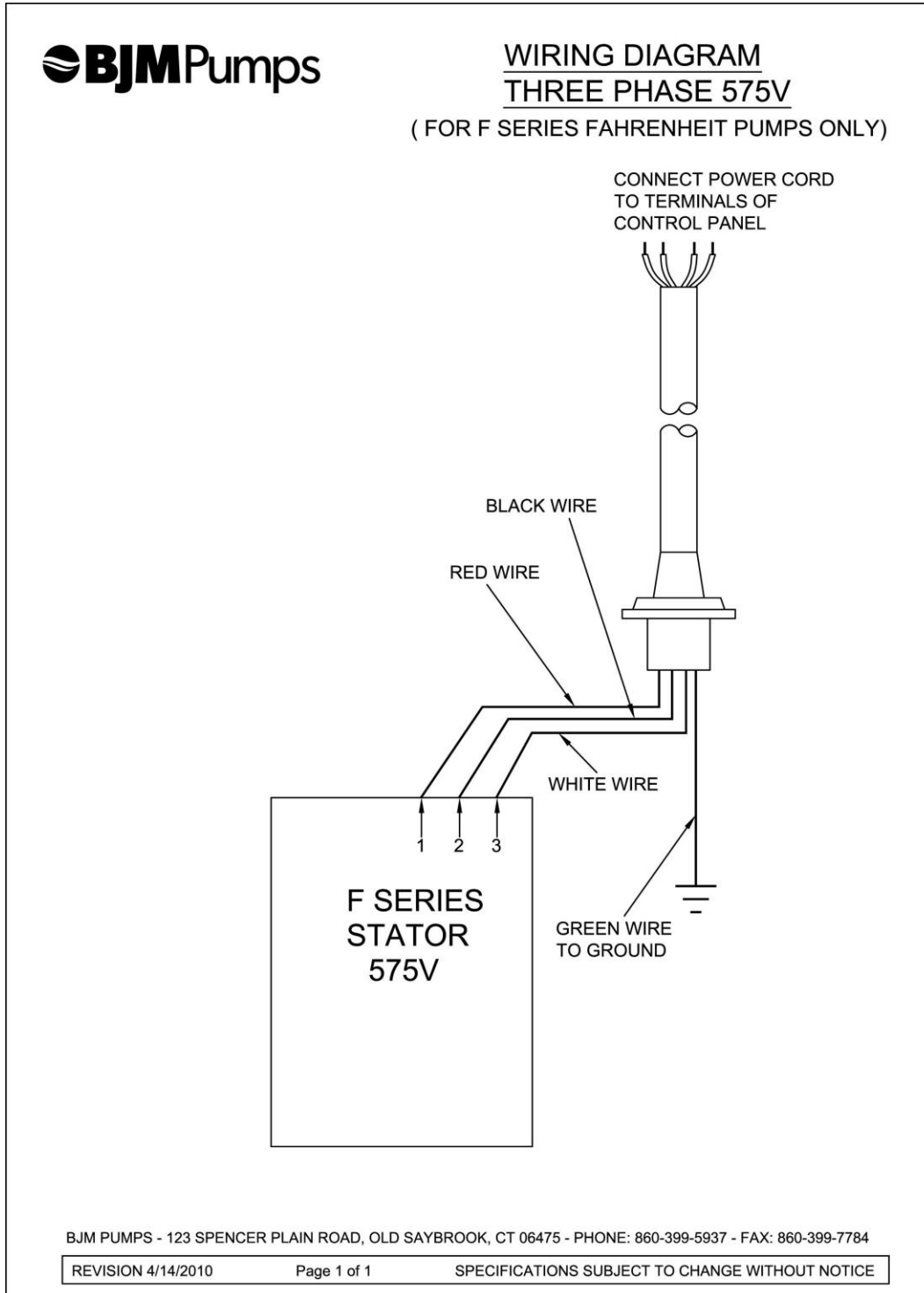

MODELS KB55-F, 55H-F, 75-F, 75R-F, 110-F, 110H-F



SEAL MINDER® - THERMAL MOTOR SENSOR SWITCH

(For high temperature pump models)

Seal Minder:

Also known as a seal failure circuit (or moisture detection circuit) is designed to inform the pump operator that there is moisture within the oil chamber. This early warning can allow the operator to schedule repair & inspection on the pump. The **Seal Minder** sensor probe is inside the oil chamber. (The oil chamber houses the mechanical seals that are cooled & lubricated by oil). The **Seal Minder**, when properly connected to a control panel, can help indicate seal failure. The **Seal Minder** cord requires a seal fail circuit in control panel for warning signal.

Along, with the **Seal Minder**, the **FAHRENHEIT**® Series high temperature pumps also feature thermal temperature sensor switches that are imbedded into the motor stator windings. Three switches are imbedded into the stator windings and wired in series. The leads are connected to the pump control panel through the sensor cable. If the windings would see a temperature above 300 degrees F, then the switch(s) would open and cut power to the pump. Once the temperature dropped below 300 degrees F, the switch(s) would reset, and the pump would be returned to a state of operation. This feature is designed to prevent damage to the stator winding and allow for longer pump life.

The sensor cable consists of four leads, two are connected to the **Seal Minder**, and two are connected to the thermal sensor switches located in the stator windings. These four leads run to the pump control panel and connect to the proper connections points for seal alarm and thermal cut off. The black and white wires are for the **Seal Minder** connections and the thermal sensors will be connected to the yellow and red wires. The three phase automatic wiring diagram shown earlier in the manual will give a guide to the connections in the control panel. The manual for the control panel should be consulted for the exact connections.

The sensor cable with **Seal Minder** and thermal sensor switch connections is standard on all **FAHRENHEIT**® Series high temperature pumps. The cable is designed for a high temperature environment. The proper replacement part can be found parts list found in this manual. BJM Pumps, can supply a control with the Seal Minder and Thermal sensor switch option. Separate stand alone Seal Minder alarm panels are also available. Consult your BJM Pumps representative for part numbers and ordering details. BJM Pumps requires the **Seal Minder** and thermal sensor switches be used. Failure to connect or misuse of these devices will void warranty.

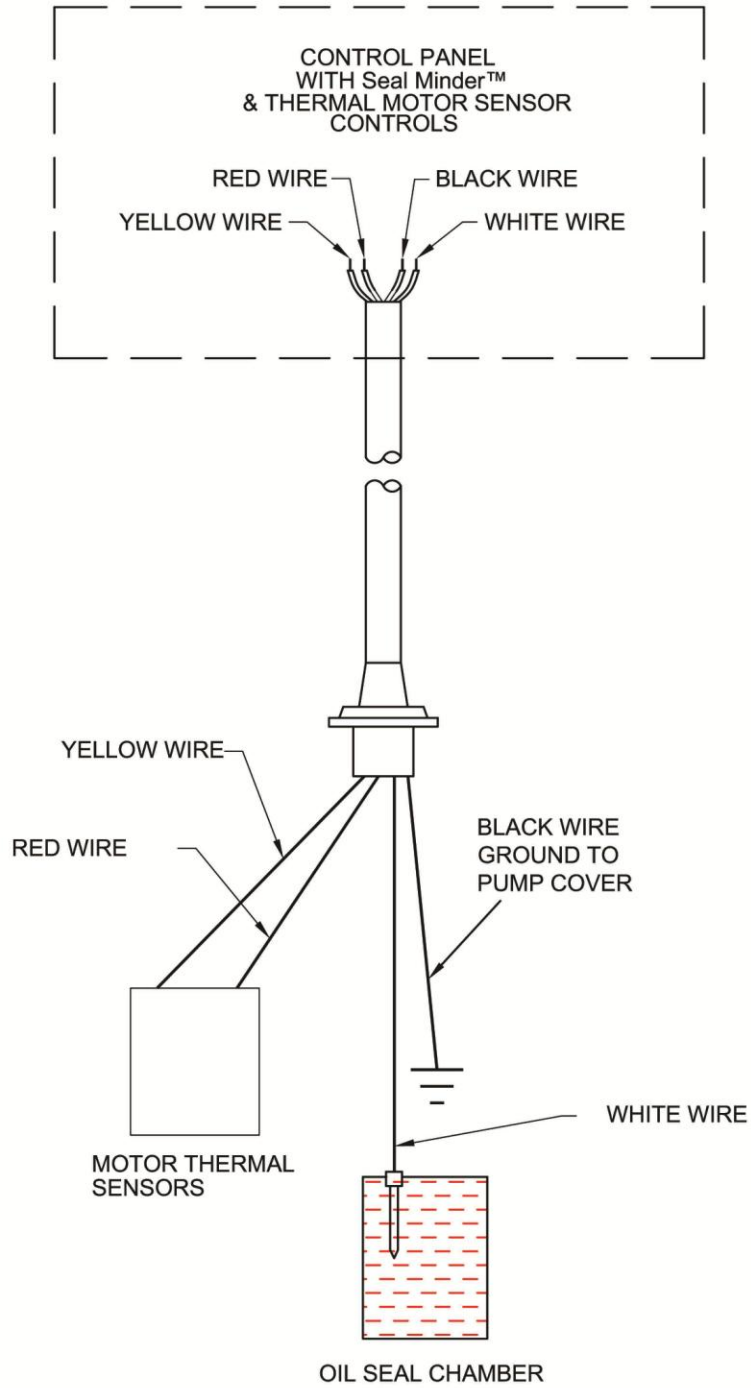

SPECIFICATIONS SUBJECT TO CHANGE WITHOUT NOTICE.

BJM Pumps, LLC - 123 SPENCER PLAIN ROAD, OLD SAYBROOK, CT 06475 - PHONE: 860-399-5937 - FAX: 860-399-7784

BJM Pumps, LLC



123 Spencer Plain Road
Old Saybrook, CT 06475, U.S.A.

WARRANTY AND LIMITATION OF LIABILITY

Unless otherwise expressly authorized in writing, specifying a longer or shorter period, BJM Pumps, LLC warrants for a period of eighteen (18) months from the date of shipment from the Point of Shipment, or one (1) year from the date of installation, whichever occurs first, that all products or parts thereof furnished by BJM Pumps, LLC under the brand name **BJM Pumps**, hereinafter referred to as the "Product" are free from defects in materials and workmanship and conform to the applicable specification.

BJM Pumps, LLC's liability for any breach of this warranty shall be limited solely to replacement or repair, at the sole option of BJM Pumps, LLC, of any part or parts of the Product found to be defective during the warranty period, provided the Product is properly installed and is being used as originally intended. Any breach of this warranty must be reported to BJM Pumps, LLC or BJM Pumps, LLC's authorized service representative within the aforementioned warranty period, and defective Product or parts thereof must be shipped to BJM Pumps, LLC or BJM Pumps, LLC's authorized representative, transportation charges prepaid. Any cost associated with removal or installation of a defective Product or part is excluded.

IT IS EXPRESSLY AGREED THAT THIS SHALL BE THE SOLE AND EXCLUSIVE REMEDY OF BJM PUMPS, LLC'S DISTRIBUTORS AND CUSTOMERS. UNDER NO CIRCUMSTANCES SHALL BJM PUMPS, LLC BE LIABLE FOR ANY COSTS, LOSS, EXPENSE, DAMAGES, SPECIAL DAMAGES, INCIDENTAL DAMAGES OR CONSEQUENTIAL DAMAGES ARISING DIRECTLY OR INDIRECTLY FROM THE DESIGN, MANUFACTURE, SALE, USE OR REPAIR OF THE PRODUCT, WHETHER BASED ON WARRANTY, CONTRACT, NEGLIGENCE, OR STRICT LIABILITY. IN NO EVENT WILL LIABILITY EXCEED THE PURCHASE PRICE OF THE PRODUCT.

THE WARRANTY AND LIMITS OF LIABILITY CONTAINED HEREIN ARE IN LIEU OF ALL OTHER WARRANTIES AND LIABILITIES, EXPRESSED OR IMPLIED. ALL IMPLIED WARRANTIES OF MERCHANTABILITY AND FITNESS FOR A PARTICULAR PURPOSE ARE HEREBY DISCLAIMED BY BJM PUMPS, LLC AND EXCLUDED FROM THIS WARRANTY.

BJM Pumps, LLC neither assumes, nor authorizes any person to assume for it, any other warranty obligation in connection with the sale of the Product. This warranty shall not apply to any Product or parts of Product which have (a) been repaired or altered outside of BJM Pumps, LLC's facilities unless such repair was authorized in advance by BJM Pumps, LLC or by its authorized representative; or (b) have been subject to misuse, negligence or accident; or (c) have been used in a manner contrary to BJM Pumps, LLC's instruction.

In any case of products not manufactured and sold under the BJM Pumps, LLC brand name, there is no warranty from BJM Pumps, LLC; however BJM Pumps, LLC will extend any warranty received from BJM Pumps, LLC's supplier of such products.

START-UP REPORT FORM

START-UP REPORT FORM

This form is designed to record the initial installation, and to serve as a guide for troubleshooting at a later date (if needed).

BJM Pumps, LLC
123 Spencer Plain Road
Old Saybrook, CT. 06475

Pump Owner's Name			
Location of Installation			
Person in Charge		Phone()	
Purchased From			
Model		Serial No	
Voltage	Phase	Hertz	HP
Does impeller turn freely by hand?	<input type="checkbox"/> Yes <input type="checkbox"/> No		
Condition of Equipment	<input type="checkbox"/> New <input type="checkbox"/> Good <input type="checkbox"/> Fair <input type="checkbox"/> Poor		
Condition of Cable Jacket	<input type="checkbox"/> New <input type="checkbox"/> Good <input type="checkbox"/> Fair <input type="checkbox"/> Poor		
Rotation: Direction of Impeller Rotation (Use C/W for clockwise, CC/W for counterclockwise):			

Method used to check rotation (viewed from bottom) _____			
Resistance of cable and Pump Motor (measured at pump control)			
Red-Black_____ ohms	Red-White_____ ohms	White-Black____ohms	
Resistance of ground circuit between control panel and outside of pumps			
_____ Ohms			
MEG OHM CHECK OF INSULATION			
Red to ground_____ White to ground_____ Black to ground_____			
Condition of location at start-up	<input type="checkbox"/> Dry <input type="checkbox"/> Wet <input type="checkbox"/> Muddy		
Was equipment stored	<input type="checkbox"/> Yes <input type="checkbox"/> No.		
If YES, length of storage:			
Liquid being pump			
Debris in bottom of station?	<input type="checkbox"/> Yes <input type="checkbox"/> No		
Was debris removed in your	<input type="checkbox"/> Yes <input type="checkbox"/> No		

START-UP REPORT FORM

presence?		
Are guide rails exactly vertical?	<input type="checkbox"/> Yes	<input type="checkbox"/> No
Is base elbow installed level?	<input type="checkbox"/> Yes	<input type="checkbox"/> No
Liquid level controls: Model _____		
Is control installed away from turbulence?	<input type="checkbox"/> Yes	<input type="checkbox"/> No
Operation Check		
Tip lowest float (stop float), all pumps should remain off. Tip second float (and stop float), one pump comes on. Tip third float (and stop float), both pumps on (alarm on simplex). Tip fourth float (and stop float), high level alarm on (omit on simplex).		
If not on levels controls, describe type of controls		
Does liquid level ever drop below volute top?	<input type="checkbox"/> Yes	<input type="checkbox"/> No
Control Panel MFG & model no.		
Number of pumps operated by control panel		
NOTE: At no time should hole be made in top of control panel, unless proper sealing devices are utilized.		
Short Circuit protection:	Type:	
Number and size of short circuit device(s)	Amp rating:	
Overload type:	Size:	Amp rating:
Do protective devices comply with pump motor amp rating?	<input type="checkbox"/> Yes	<input type="checkbox"/> No
Are all pump connections tight?	<input type="checkbox"/> Yes	<input type="checkbox"/> No
Is the interior of the panel dry?	<input type="checkbox"/> Yes	<input type="checkbox"/> No If No, correct moisture problem.
Electrical readings		
SINGLE PHASE		
Voltage supply at panel line connection, pump off	L1	L2
Voltage supply at panel line connection, pump on	L1	L2
Amperage load connection, pump on	L1	L2
THREE PHASE		
Voltage supply at panel line connection, pump off		
L1-L2	L2-L3	L3-L1

START-UP REPORT FORM

Voltage supply at panel line connection, pump on		
L1-L2	L2-L3	L3-L1
Amperage load connection, pump on		
L1	L2	L3
FINAL CHECK		
Is pump secured properly?	<input type="checkbox"/> Yes <input type="checkbox"/> No	
Was pump checked for leaks?	<input type="checkbox"/> Yes <input type="checkbox"/> No	
Do check valves operate properly?	<input type="checkbox"/> Yes <input type="checkbox"/> No	
Flow: Does station appear to operate at proper rate?	<input type="checkbox"/> Yes <input type="checkbox"/> No	
Noise level:	Acceptable <input type="checkbox"/>	Unacceptable <input type="checkbox"/>
Comments:		
Describe and equipment difficulties during start-up		
Installed by: Company: _____ Person: _____ Date: _____		
Maintained by: Company: _____ Person: _____		
Date and time of start-up _____ Present at start-up: () Engineer's name _____ () Contractor's name _____ () Operator's name _____ () others _____		

BJM Pumps, LLC
123 Spencer Plain Road • PO Box 1138 • Old Saybrook, CT 06475, USA
• Phone: (860) 399-5937 • Fax: (860) 399-7784
Email: sales@bjmpumps.com • Web Site: www.bjmpumps.com

FARWENHET[®] is a trademark of BJM Pumps, LLC.
BJM Pumps & Seal Minder is a registered trademark of BJM Pumps, LLC
Copyright © 2009-2018 BJM Pumps, LLC. All rights reserved